



# ECLIPSE Ji

SMART IMAGING SYSTEM



# Research Microscope Power in a Benchtop Assay Instrument

## Simple Operation

Minimal interaction and complexity by AI-tuned assays and analysis.

## Easy Cellular Imaging

No need to use complicated microscope hardware and software — ECLIPSE Ji makes data collection and cellular imaging assays easy.

## Nikon Optical Quality

Renowned Nikon optics provide clear and sharp images on plate assay devices.



◀ Introduction video

# Smart Experiments with Automated Assays

Utilizing Nikon's precision optical hardware, all of the advantages of high sensitivity and resolution from a research-level microscope is embedded into an AI-driven, easy to operate benchtop laboratory Instrument.



Preconfigured and optimized turnkey assay experiments minimize time defining parameters and maximize data collection.

### Standard Assays

**Intensity Measurement**  
Compares protein expression level changes in cells and cell nuclei in multiple wells.

**Size & Morphological analysis**  
Analyze morphology with measurements of the cell nucleus, cytoplasm, and the size of the cell region.

**Cell Counting (endpoint)**  
Measure the number of cell nuclei in a fixed sample and the area of the well occupied by cells.

**Transfection Efficiency**  
Investigate the percentage of cells expressing the target protein, and measure efficiency of expression of a specific gene.

**Cytotoxicity**  
Measure the percentage of dead cells among all cells and evaluate cytotoxicity.

### Optional Assays

**Apoptosis**  
Measure the percentage of cell apoptosis.

**Nuclear Translocation**  
Measure the nuclear translocation of NF- $\kappa$ B that received an extra-cellular stimulus.

**DNA damage (gamma H2AX)**  
Measure the damage that occurred in DNA in the cell's nucleus.

**Autophagy**  
Measure the number of autophagosomes, their area, and the fluorescence intensity.



For the latest assay list, please refer to our website.



ECLIPSE Ji fits standard laboratory benchtops, has built-in vibration dampening hardware, and works in bright environments. There is no need for dedicated space or dark rooms to perform efficient imaging assays.

# Effortless Results using AI

ECLIPSE Ji's Smart Experiment software interface uses newly developed artificial intelligence (AI), implemented to minimize errors and maximize data collection.

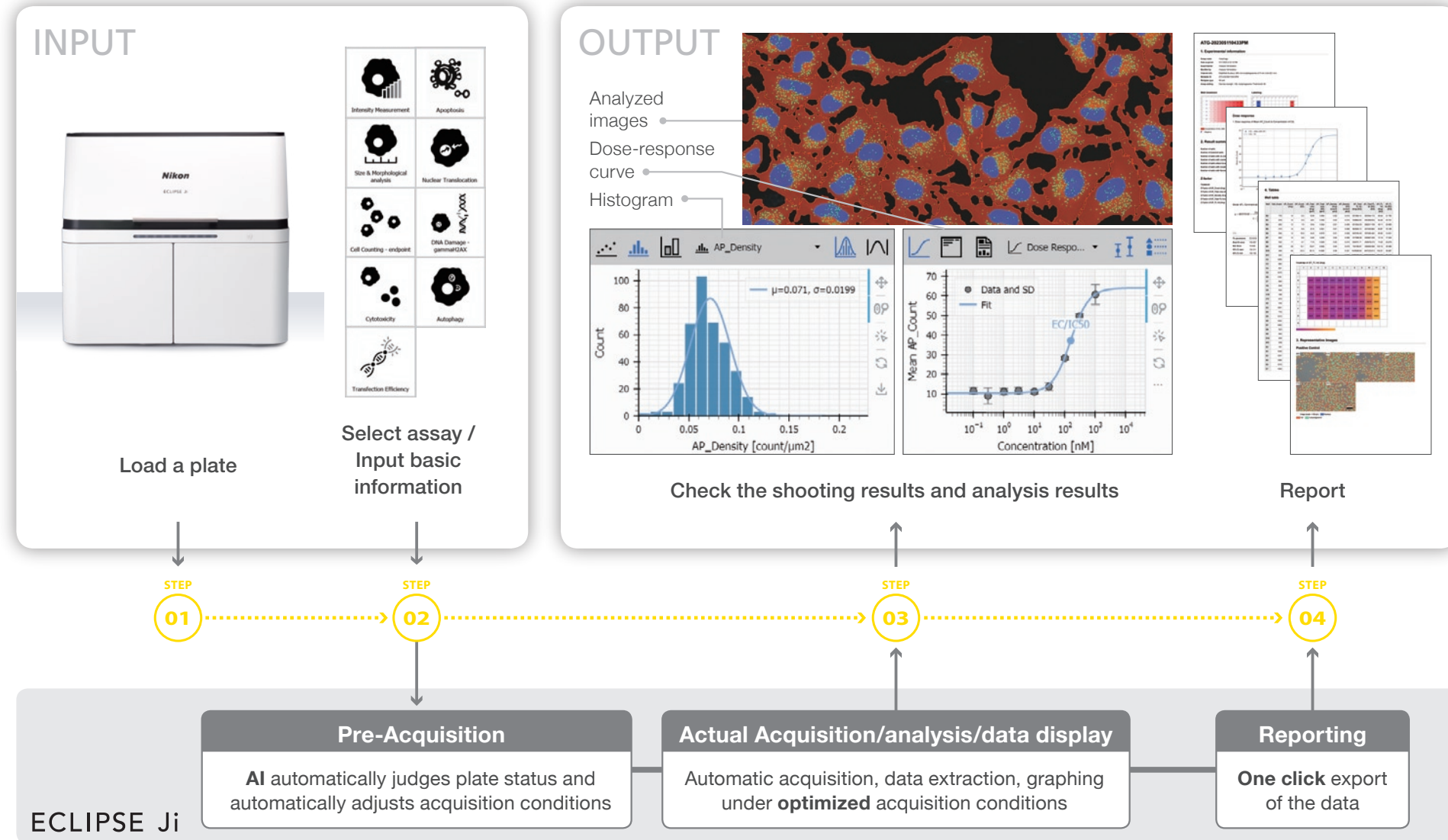

# Cellular Data and Imaging with ease

AI based on Deep Learning defines acquisition settings and image analysis parameters, saving researchers valuable time at the microscope.

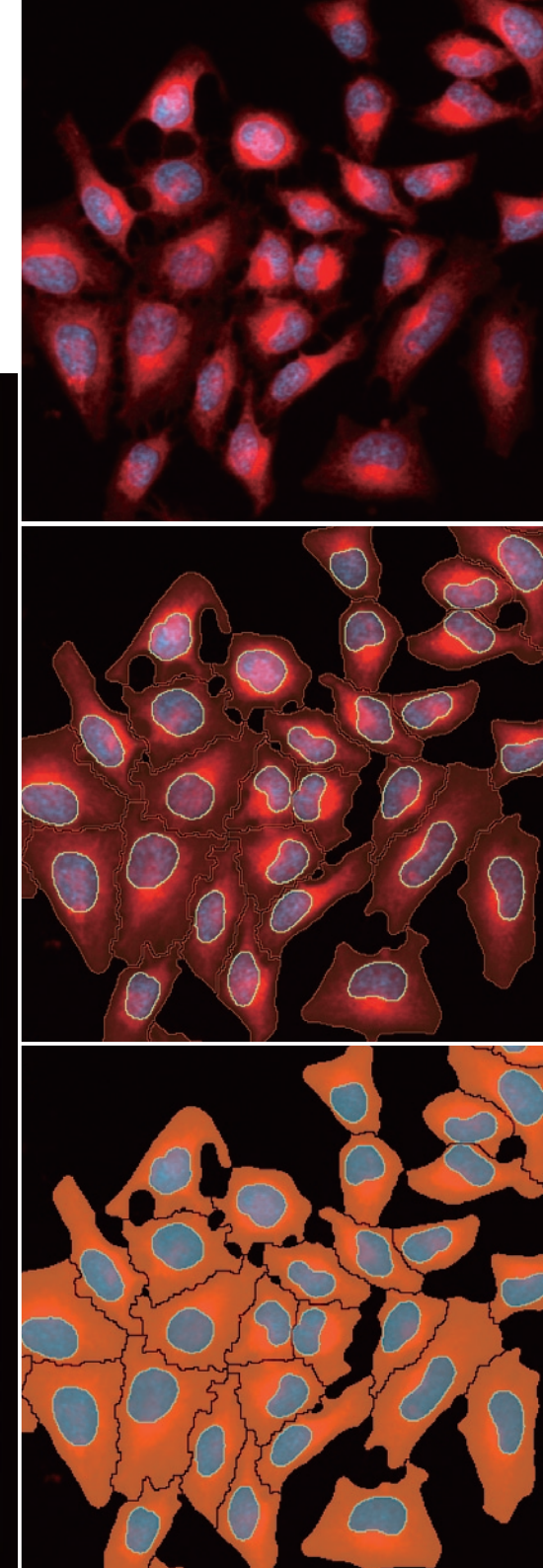
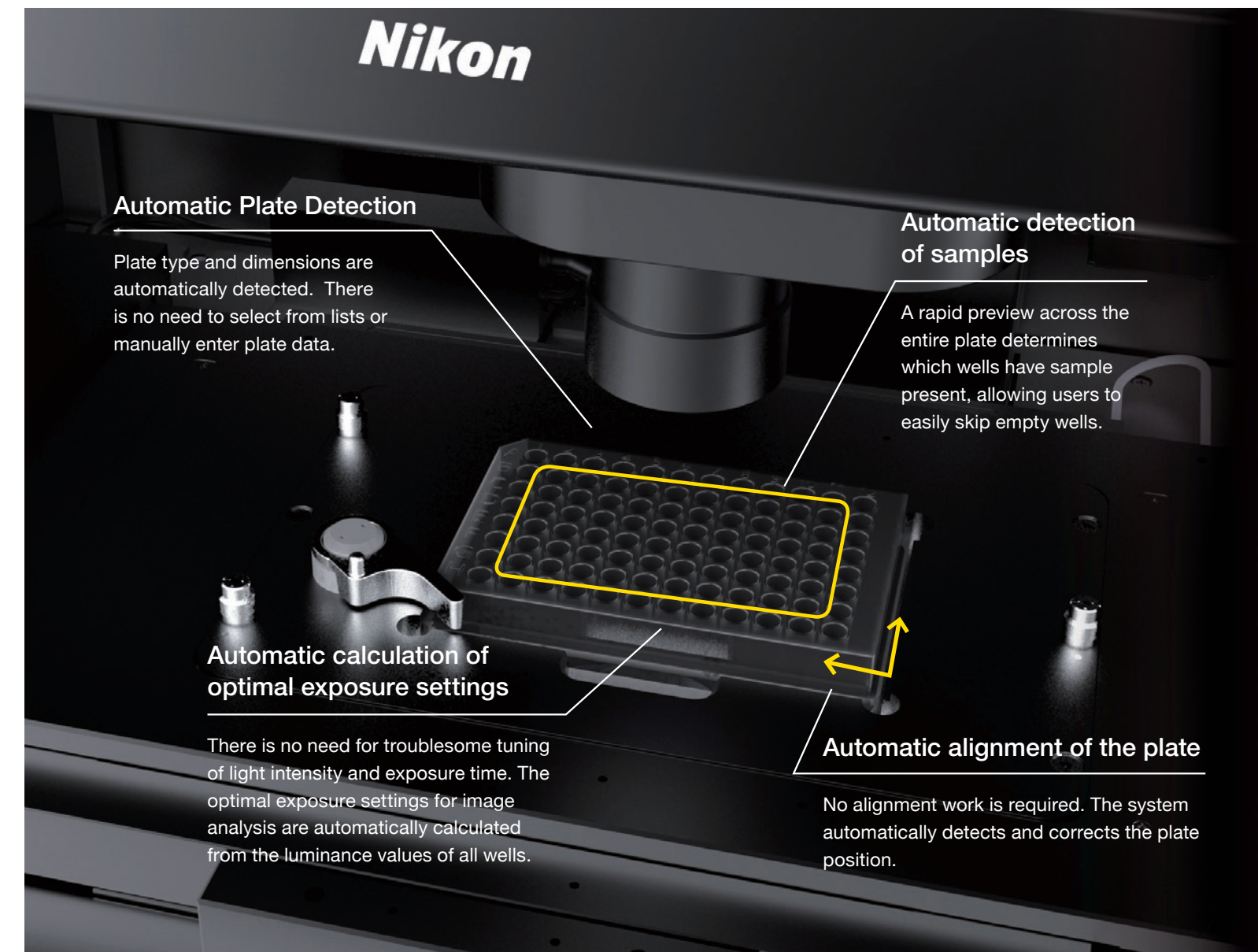

# User Interface designed for Rich Data Microscope

Images and corresponding analysis data for the plate, well, and each cell is contained in an interactive and linked interface. Users can navigate and quickly visualize trends and results.

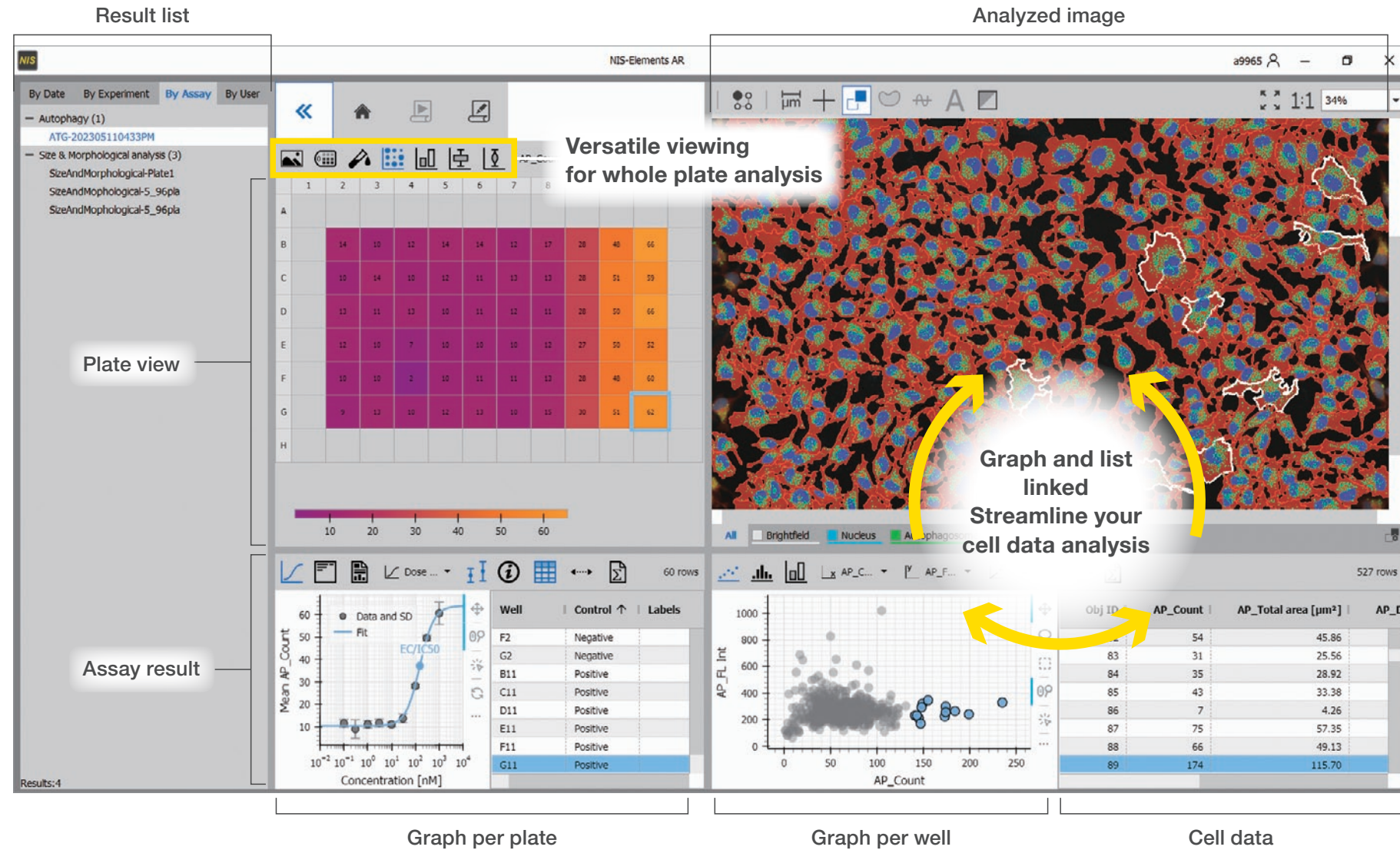

# ECLIPSE Ji: a Multi-Role Digital Inverted Navigation

Outside of plate assays, ECLIPSE Ji can also serve as a digital research microscope, and can be integrated with a variety of peripherals including filter wheels, other detectors such as "AX", or high sensitive cameras.

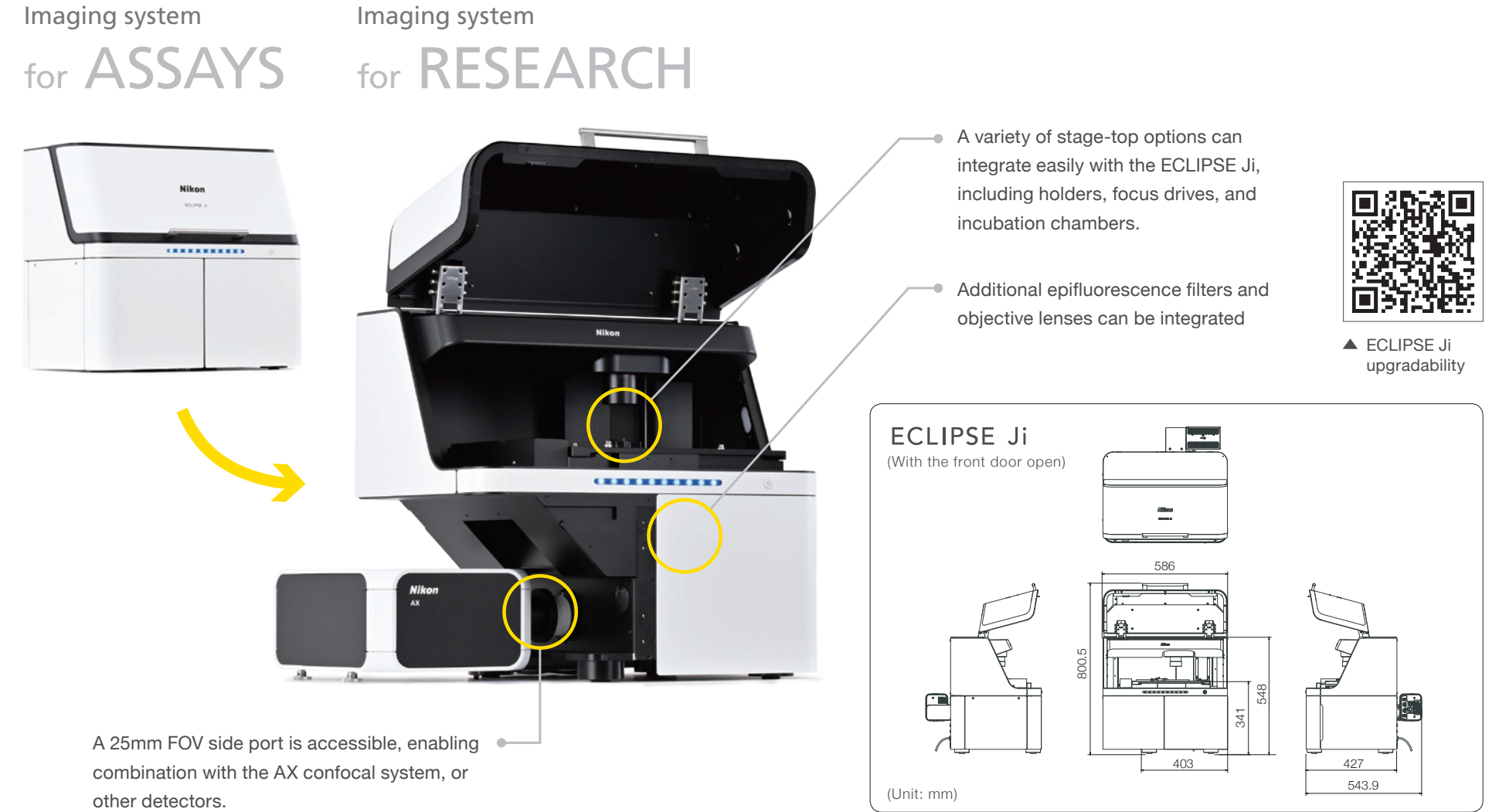

## Specifications

Model name	ECLIPSE Ji
Observation methods	Brightfield, Epi-fluorescence
Optical system	CFI Infinity Optical System Observation Optical System: Inverted image observation, FOV 25 Optical path switching: Switching between the built-in camera optical system and the left side port
Built-in camera	Imaging device: 7.8 megapixel monochrome CMOS sensor Output signal Tone: Monochrome 12 bits/8 bits Frame rate: Maximum 18 fps Output pixel number: 2800×2800 pixels (when assay used)
Focusing	Drive system: Motorized (Via PFS nosepiece objective lens up/down movement) Focusing stroke: About 10 mm Focusing speed: Maximum driving speed 2.5 mm/sec
PFS*	Focal point maintenance control: Infrared light projecting method Applicable observation methods: Brightfield, Fluorescence observation
Transmission illumination section	Koehler illumination Light source: LED
Stage	Stroke: X: ±59 mm, Y: ±39.5 mm Maximum drive speed About 25 mm/sec
Nosepiece	Objective lens mounting holes: 6 Nosepiece drive method: Motorized
Fluorescence cube turret	Number of filter cubes that can be mounted: 6 (Compatible with wide-field filter cubes) Turret drive method: Motorized
Light distribution section	Light source used: D-LEDi2 fluoresce LED light source
PC interface	USB interface: Device interface (for built-in camera) B connector USB 3.0 (SuperSpeed)
Input rating	100V-240VAC±10%, 3.0 A, 50/60 Hz
Power consumption	320 W
Power source cord	- 100 to 120 V: Power source cord of 3 conductor grounding Type SVT, NO.18 AWG, 3 m long maximum, rated at 125VAC minimum with detachable receptacles conforming to UL specifications  - 220 to 240 V: Power source cord of 3 conductor grounding Type H05VV-F 1 mm <sup>2</sup> , 3 m long maximum, rated at 250VAC minimum with detachable receptacles conforming to EU/EN specifications

\*PFS: a function that automatically corrects focal point displacement due to the passage of time and/or stage movement.

## System Diagram

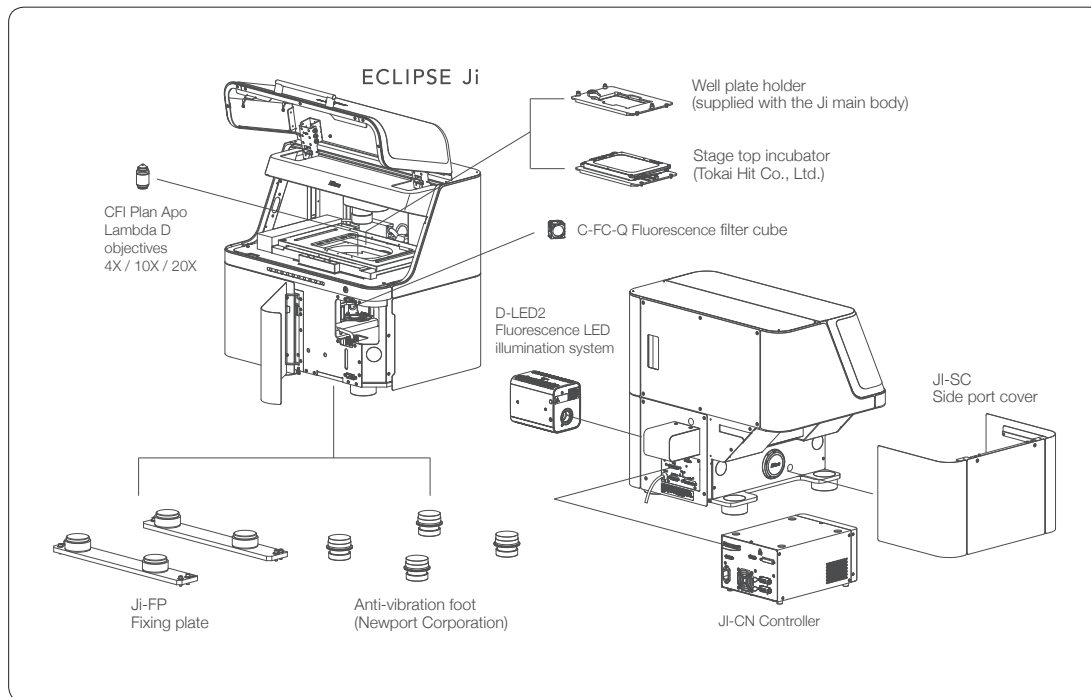

**Specifications and equipment are subject to change without any notice or obligation on the part of the manufacturer. July 2024 ©2023-2024 NIKON CORPORATION**

N.B. Export of the products\* in this brochure is controlled under the Japanese Foreign Exchange and Foreign Trade Law. Appropriate export procedures shall be required in case of export from Japan.  
\*Products: Hardware and its technical information (including software)



**WARNING**

TO ENSURE CORRECT USAGE, READ THE CORRESPONDING MANUALS CAREFULLY BEFORE USING THE EQUIPMENT.



### NIKON CORPORATION

Head office  
1-5-20, Nishiio, Shinagawa-ku, Tokyo, 140-8601, Japan  
<https://www.healthcare.nikon.com/en/>

Manufacturer  
471, Nagaodai-cho, Sakae-ku, Yokohama,  
Kanagawa 244-8533, Japan

ISO 14001 Certified  
for NIKON CORPORATION

**Nikon Instruments Inc.**  
1300 Walt Whitman Road, Melville, N.Y. 11747-3064, U.S.A.  
phone: +1-631-547-8500; +1-800-52-NIKON (within the U.S.A. only)  
fax: +1-631-547-0299

<https://www.microscope.healthcare.nikon.com/>  
**Nikon Europe B.V.**  
Stroombaan 14, 1181 VX Amstelveen, The Netherlands  
phone: +31-20-7099-000

[https://www.microscope.healthcare.nikon.com/en\\_EU/](https://www.microscope.healthcare.nikon.com/en_EU/)  
**Nikon Precision (Shanghai) Co., Ltd.**  
CHINA phone: +86-21-6841-2050 fax: +86-21-6841-2060  
(Beijing branch) phone: +86-10-5831-2028 fax: +86-10-5831-2026  
(Guangzhou branch) phone: +86-2-3882-0551 fax: +86-2-3882-0580  
<https://www.nikon-precision.com.cn/>

**Nikon Canada Inc.**  
CANADA phone: +1-905-625-9910 fax: +1-905-602-9953

**Nikon France, Succursale de Nikon Europe B.V.**  
FRANCE phone: +33-1-4516-4516

**Nikon Deutschland, Zweigniederlassung der Nikon Europe B.V.**  
GERMANY phone: +49-211-9414-888

**Nikon Italy, Branch of Nikon Europe B.V.**  
ITALY phone: +39-055-300-9601

**Nikon Europe B.V. Amstelveen, Zweigniederlassung Schweiz (Egg/ZH)**  
SWITZERLAND phone: +41-43-277-2867

**NIKON UK, Branch of Nikon Europe B.V.**  
UNITED KINGDOM phone: +44-208-247-1717

**Nikon Österreich, Zweigniederlassung der Nikon Europe B.V.**  
AUSTRIA phone: +43-1-972-6111

**Nikon Singapore Pte Ltd**  
SINGAPORE phone: +65-6559-3651 fax: +65-6559-3668

**Nikon Australia Pty Ltd**  
AUSTRALIA phone: +61-2-8767-6900

**Nikon Instruments Korea Co., Ltd.**  
KOREA phone: +82-2-6288-1900 fax: +82-2-555-4415

**NIKON INDIA PVT. LTD.**  
AUSTRALIA phone: +91-124-4688-500